

# Vestil

## Quality Assurance and Deviation Inspection Sheet

Cart 400, 650LT, 800D, 1000, 1500

Cart Model	1000
Manufacture Date	2005.01
Inspectors Name	PAN
Inspection Date	2005.01
Empty Tests	
Number strokes up	14
Down Time	9 Seconds
Maximum Height	35.8 Inches
Minimum Height	15.4 Inches
Weight Tests	
Number strokes HS	39
Number of strokes LS	5
Shift Weight	1100 Pounds
Test Weight	1210 Pounds
Down Time	7 Seconds
Leak Test (hold full load for 15min w/out drift down)	YES/NO
Acceptable (Reasons if Not)	YES/NO
Deviations from Norm	

## TF30C/TF50C TWO SPEED HYDRAULIC TABLE TRUCK

No.	Description	Q'ty	No.	Description	Q'ty	No.	Description	Q'ty
1	Table	1	35	Hex Cap Bolt	4	15)	Adjust Pressure Plug	1
2	Link Assembly	1	36	Cylinder	1	16)	O-ring	1
3	Shaft	2	37	Safe Valve	1	17)	Adjust Pressure Plug	1
4	Bushing	4	38	O-ring	1	18)	Spring Seat	1
5	C-ring	8	39	Oil Pipe Tie-in	1	19)	Steel Ball	1
6	Shaft	2	40	High Pressure Oil Pip	1	20)	O-ring	1
7	Roller Guide	4	41	C-ring	1	21)	Oil Pip Tie-in	1
8	Handle	1	42	Shaft	1	22)	Steel Ball	1
9	Brake Thread	1	43	Hex Cap Nut	1	23)	Fastigate Spring	1
10	Brake Handle	1	44	Spring Washer	1	24)	O-ring	1
11	Hex Cap Screw	2	45	Ward board	1	25)	Hex Cap Plug	1
12	Spring Washer	2	46	Lift Piston	1	26)	Lowering Valve	1
13	Flat Washer	2	47	Shaft	1	27)	O-ring	1
14	Support Holder	1	48	C-ring	2	28)	O-ring	1
15	Set Screw	1	49	O-ring	1	29)	Hex Cap Plug	1
16	Hex Cap Nut	1	50	Top Nut	1	30)	Spring	1
17	Spring Pin	1	51	Oil Seal	1	31)	Shaft	1
18	Set Screw	1	52	Oil Seal	1	32)	C-ring	2
19	Hex Cap Nut	1	53	O-ring	1	33)	O-ring	1
20	Pressure Board	1	54	Dust Cover	1	34)	Pump Cylinder	1
21	Hex Cap Screw	2	1)	Valve	1	35)	O-ring	1
22	Frame Seat (TF30) Frame Seat (TF50)	1	2)	Top Rod	1	36)	Dust Cover	1
23	Spring Washer	8	3)	O-ring	1	37)	Oil Seal	1
24	Flat Washer	8	4)	Spring	1	38)	Lift Piston	1
25	Hex Cap Bolt	8	5)	Steel Ball	2	39)	Big Spring	1
26	Set Nut	4	6)	O-ring	1	40)	Spring Seat	1
27	Swivel Wheel Holder	2	7)	Hex Cap Plug	1	41)	C-ring	1
28	Big Wheel	4	8)	Hex Cap Plug	2	42)	Foot Pedal Holder	1
29	Protect Cover	2	9)	O-ring	2	43)	Foot Pedal Holder	1
30	Flat Washer	2	10)	Spring	1	44)	Foot Pedal Rod	1
31	Spring Washer	2	11)	Steel Ball	1	45)	Pressure wheel	1
32	Semicircle Screw	2	12)	Hex Cap Bolt	2	46)	Shaft	1
33	Bearing	8	13)	Spring Washer	2	47)	Shaft	1
34	Washer	4	14)	Hex Cap Plug	1	48)	C-ring	4

# TF30C/TF50C TWO SPEED HYDRAULIC TABLE TRUCK

## I. Use & applicable range

It is a convertible vehicle using for lifting and transporting in workshop, warehouse and wharf, etc.

## II. Basic Data

Model	TF30C	TF50C
Load Capacity	300kgs	500kgs
Lift Height	900mm	900mm
Lowest Height	280/385mm	290/390mm
Table Dimensions	825×500×50mm	825×500×55mm
Packing Dimensions	1000×520×400mm	1000×520×400mm
Net Weight	78kgs	84kgs

## III. Characteristics

This cart adopts mechanical change structure to lift the table by low speed or fast speed. When the loading is light, you can foot the pedal to lift the table by fast speed way. It is about twelve times to lift the table to the max height. When the loading is much heavy, you can foot the pedal to lift the table by low speed way. It is about thirty-five times to lift the table to the max height. You can change the lift speed according to different loading.

## IV. Assembly

4. Insert handle (#12) into the hole of the frame seat (#26), and then fix them by two hex cap bolts M10.
5. The brake thread (#13) through the hole of the press board (#19), adjust the degree of tightness and then fix them by Nut (#24).
6. Insert the foot pedal rod (#44) into the hole of the foot pedal support (#42), and fix them by screw.

## V. Using

1. Please debug the cart before using: Step on the foot pedal rod equably to lift the table.
2. Please lock the brake on the wheel and fix the table before loading.
3. Please load goods in its rate capacity. You can load or discharge after the table to the height which you need by step the foot pedal.
4. Please use the brake handle (#14) to lower down the table.

## VI. Warning!

- 1 Operate strictly according to the instruction manual.
2. Do not use the cart on slop.
3. Do not allow people to sit or ride on the cart.
4. Do not transport the loads during the raising process.
5. Do not random regulate the safety valve.
6. The maintenance is to be performed by the professional personnel strictly according to the related information of the instruction manual.
7. Keep oil clean. Check the oil reservoir in the hydraulic cylinder before operate and replenish reservoir if oil does not reach 2/3 of the capacity.
8. The hydraulic system adopts machinery oil #32. Replace the oil once in the first month and then regularly replace the oil every six month.

# TF30C/TF50C

No	Description	QTY
1	Table	1
2	Link Assembly	1
3	Shaft	1
4	Cap Bolt	1
5	High Pressure Oil Plug	2
6	Shaft	1
7	Cap Bolt	1
8	Swivel Wheel Holder	1
9	Hex Cap Bolt	1
10	Hex Cap Bolt	1
11	Hex Cap Bolt	1
12	Hex Cap Bolt	1
13	Hex Cap Bolt	1
14	Hex Cap Bolt	1
15	Hex Cap Bolt	1
16	Hex Cap Bolt	1
17	Hex Cap Bolt	1
18	Hex Cap Bolt	1
19	Hex Cap Bolt	1
20	Hex Cap Bolt	1
21	Hex Cap Bolt	1
22	Hex Cap Bolt	1
23	Hex Cap Bolt	1
24	Hex Cap Bolt	1
25	Hex Cap Bolt	1
26	Hex Cap Bolt	1
27	Hex Cap Bolt	1
28	Hex Cap Bolt	1
29	Hex Cap Bolt	1
30	Hex Cap Bolt	1
31	Hex Cap Bolt	1
32	Hex Cap Bolt	1
33	Hex Cap Bolt	1
34	Hex Cap Bolt	1
35	Hex Cap Bolt	1
36	Hex Cap Bolt	1
37	Hex Cap Bolt	1
38	Hex Cap Bolt	1
39	Hex Cap Bolt	1
40	Hex Cap Bolt	1
41	Hex Cap Bolt	1
42	Hex Cap Bolt	1
43	Hex Cap Bolt	1
44	Hex Cap Bolt	1
45	Hex Cap Bolt	1
46	Hex Cap Bolt	1
47	Hex Cap Bolt	1
48	Hex Cap Bolt	1
49	Hex Cap Bolt	1
50	Hex Cap Bolt	1
51	Hex Cap Bolt	1
52	Hex Cap Bolt	1
53	Hex Cap Bolt	1
54	Hex Cap Bolt	1

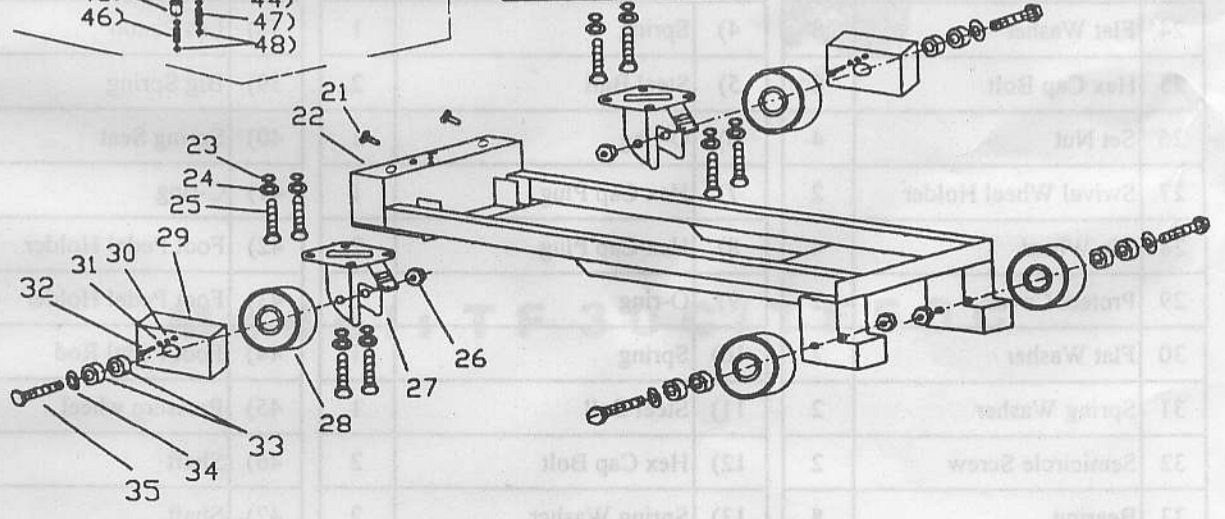
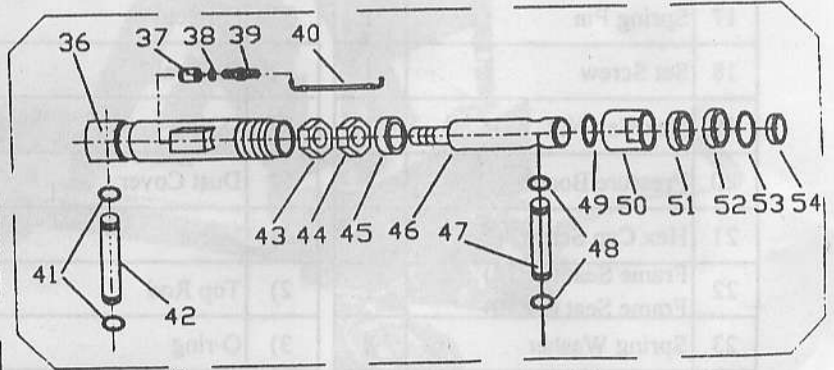
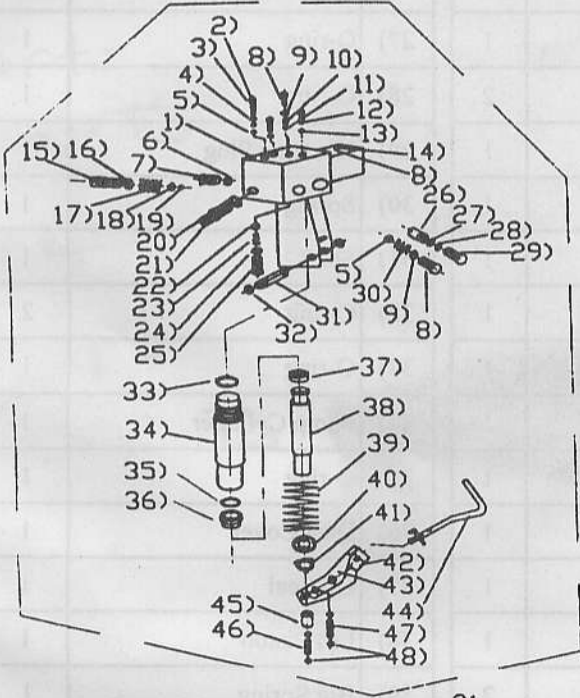
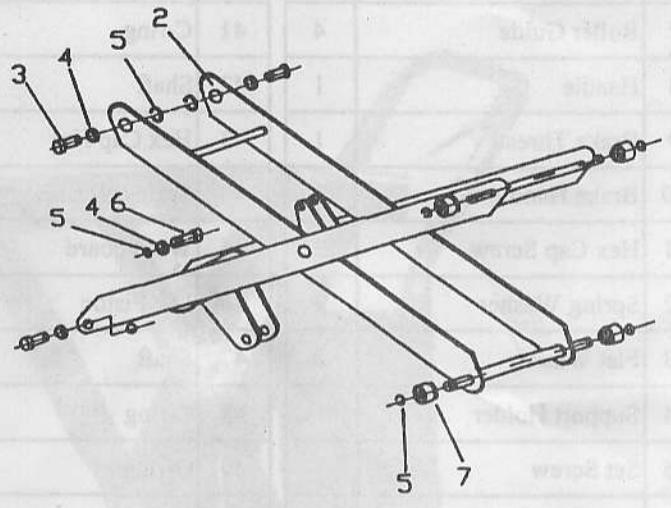
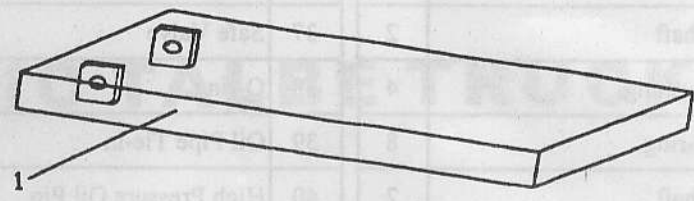
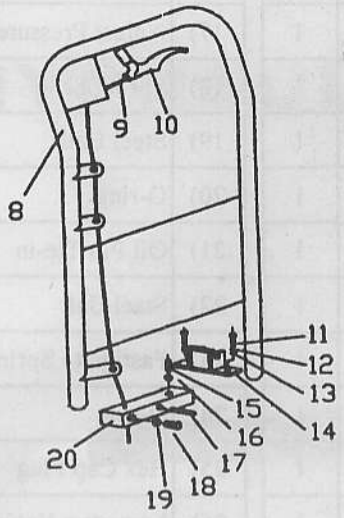

## LIMITED WARRANTY

Vestil Manufacturing Corporation (“Vestil”) warrants this product to be free of defects in material and workmanship during the warranty period. Our warranty obligation is to provide a replacement for a defective, original part covered by the warranty after we receive a proper request from the Warrantee (you) for warranty service.

### Who may request service?

Only a warrantee may request service. You are a warrantee if you purchased the product from Vestil or from an authorized distributor AND Vestil has been fully paid.

### Definition of “original part”?

An original part is a part used to make the product as shipped to the Warrantee.

### What is a “proper request”?

A request for warranty service is proper if Vestil receives: 1) a photocopy of the Customer Invoice that displays the shipping date; AND 2) a written request for warranty service including your name and phone number. Send requests by one of the following methods:

#### US Mail

Vestil Manufacturing Corporation  
2999 North Wayne Street, PO Box 507  
Angola, IN 46703

#### Fax

(260) 665-1339

#### Phone

(260) 665-7586

#### Email

[info@vestil.com](mailto:info@vestil.com)

Enter “Warranty service request”  
in the subject field.

In the written request, list the parts believed to be defective and include the address where replacements should be delivered. After Vestil receives your request for warranty service, an authorized representative will contact you to determine whether your claim is covered by the warranty. Before providing warranty service, Vestil will require you to send the entire product, or just the defective part (or parts), to its facility in Angola, IN.

### What is covered under the warranty?

The warranty covers defects in the following original, dynamic parts: motors, hydraulic pumps, motor controllers, and cylinders. It also covers defects in original parts that wear under normal usage conditions (“wearing parts”), such as bearings, hoses, wheels, seals, brushes, and batteries.

### How long is the warranty period?

The warranty period for original dynamic components is 1 year. For wearing parts, the warranty period is 90 days. Both warranty periods begin on the date Vestil ships the product to the Warrantee. If the product was purchased from an authorized distributor, the periods begin when the distributor ships the product. Vestil may, at its sole discretion, extend a warranty period for products shipped from authorized distributors by up to 30 days to account for shipping time.

### If a defective part is covered by the warranty, what will Vestil do to correct the problem?

Vestil will provide an appropriate replacement for any *covered* part. An authorized representative of Vestil will contact you to discuss your claim.

### What is not covered by the warranty?

The Warrantee (you) is responsible for paying labor costs and freight costs to return the product to Vestil for warranty service.

### Events that automatically void this Limited Warranty.

- Misuse;
- Negligent assembly, installation, operation or repair;
- Installation/use in corrosive environments;
- Inadequate or improper maintenance;
- Damage sustained during shipping;
- Collisions or other accidents that damage the product;
- Unauthorized modifications: Do not modify the product IN ANY WAY without first receiving written authorization from Vestil.

### Do any other warranties apply to the product?

Vestil Manufacturing Corp. makes no other express warranties. All implied warranties are disclaimed to the extent allowed by law. Any implied warranty not disclaimed is limited in scope to the terms of this Limited Warranty. Vestil makes no warranty or representation that this product complies with any state or local design, performance, or safety code or standard. Noncompliance with any such code or standard is not a defect in material or workmanship.

